

T型杭

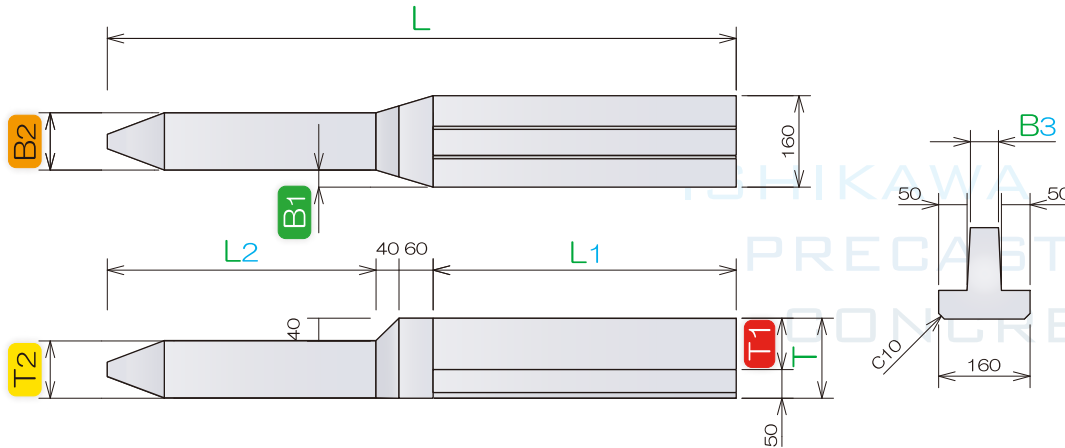
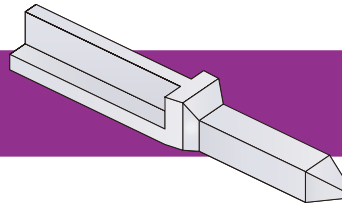

呼び名	寸法 (mm)									参考重量 (kg)
	L1	L	L2	T	T1	T2	B1	B2	B3	
600-1000	600	1000	300	160	110	120	20	120	49	33
600-1200	600	1200	500	160	110	120	20	120	49	40
600-1500	600	1500	800	160	110	120	20	120	49	51
900-1500	900	1500	500	160	110	120	20	120	49	50
900-2000	900	2000	1000	160	110	120	20	120	49	68
1200-2000	1200	2000	700	160	110	120	20	120	49	67
1200-2500	1200	2500	1200	160	110	120	20	120	49	85
1500-2500	1500	2500	900	180	130	140	10	140	47	99
1500-3000	1500	3000	1400	180	130	140	10	140	47	122
1800-3000	1800	3000	1100	180	130	140	10	140	47	119